

Earth-Rite® MGV

Mobile Ground Verification System



The **Earth-Rite®** Mobile Ground Verification system (MGV) is a unique, patented technology designed to provide automatic confirmation of a positive electrostatic ground connection for trucks collecting and transferring flammable / combustible products.

Enquiry > Click here to submit a product related query or a request for quotation.

Vacuum trucks and bulk chemical road tankers, including their hoses and hose connections, are susceptible to static charge accumulation during the transfer of product into or out of the truck's containment system. This accumulation of static charge is equivalent to a hidden source of ignition and if discharged as a static spark can lead to the ignition of the product or the atmosphere in which the truck and material handling team is operating.

To eliminate the risk of incendive static spark discharges the **API standard 2219: Safe Operation of Vacuum Trucks in Petroleum**

Service recommends that vacuum truck operators transferring flammable and combustible product in hazardous locations must fully ground the truck prior to any other task in the transfer operation by connecting the truck to a **"proven ground source"**.

The Earth-Rite MGV is designed to enable operators establish safe grounding of their vehicle in accordance with these recommended practices.



Earth-Rite MGV Mobile Grounding Verification System

Typical Grounding Applications:

- > Cleaning & material recovery operations for on-site cleaning of storage tanks and chemical spills.
- > Transporting chemicals to various stages of production on chemical manufacturing sites.
- > Transporting flammable product to external sites where installed grounding systems are not present or have not been verified by the supplier.
- > Hazmat Recovery operations recovering flammable spillages following transportation and loss of containment incidents.

Earth-Rite® MGV Mobile Ground Verification System

The **Earth-Rite** MGV system performs two system checks which ensures the vehicle can dissipate static charges for the duration of the transfer process.

1. Static Ground Verification

The MGV system ensures the connection resistance of the object that is identified as the ground source to earth, is low enough to safely dissipate static charges from the truck.

2. Continuous Ground Loop Monitoring

When the Static Ground Verification process is confirmed, the MGV system continuously monitors the connection resistance of the truck to this verified grounding point for the duration of the transfer process. This connection resistance must be maintained at 10 ohms (or less) for the duration of the transfer process.

Two output contacts located in the control unit of the MGV system can interlock with pumps or other control devices to prevent transfer operations should a static ground connection fail to be established or maintained for the transfer process.

Easy and quick Operation

Removing the need for taking manual resistance readings or interacting with complex system interfaces the operator activates the system by simply connecting the system's grounding clamp to a site designated grounding point, buried metal structure (pipes, storage tanks) or temporary points like buried grounding rods.

When the **Static Ground Verification** and **Continuous Ground Loop Monitoring** checks are positive, a cluster of attention grabbing green LEDs pulse continuously informing the operator that the truck is securely grounded.



The Earth-Rite MGV static grounding system can be mounted on vacuum trucks and tank trucks.

System Installation

- > The MGV system is powered by the vehicle's primary 24 V or 12 V battery supply with the control unit mounted on the truck chassis.
- > The system can be interlocked with the on board pump, vehicle mounted strobe lights or audible alarms to provide material handlers with additional levels of security.



Quick release static grounding clamp

supplied with the Earth Rite MGV attached to buried rod.

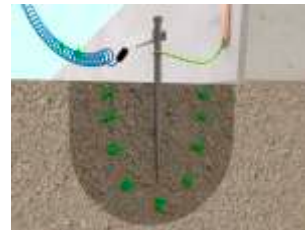

Static Ground Verification check



Continuous Ground Loop Monitoring check

Certification



Ingress Protection
IP 66

Temperature Range
13°F to +131°F CSA
40°C to +55°C ATEX /
IECEx

Power Supply
12 V or 24 V DC

Enclosure Option
Ex(d)/XP enclosure for trucks
parked in Zone 1 / Class I, Div.1

The Earth Rite® MGV forms part of the Earth Rite® range of Static Grounding and Bonding Equipment available from Newson Gale Ltd.

Earth-Rite® MGV Mobile Ground Verification System

Technical Specification

(Zone 2 Gas / Vapour Installations - Zone 21 & 22 Dust Atmospheres)

Power Supply & Monitoring Unit	
Power Supply	12 V or 24 V DC
Power Rating	10 watt
Ambient Temperature Range	40°C to +55°C
Ingress Protection	IP 66
Weight	2 kgs (4.4 lbs) nett
Construction	Carbon loaded GRP
Monitoring Circuit	Intrinsically safe
Operational Series Ground Resistance	Nominally ≤ 10 Ohm
Output Relay Contact Rating	2 off voltage free change over switch contacts, 250 V AC, 5 A, 500 VA max resistive 30 V DC, 2 A, 60 W max resistive
Cable Entries	7 x M20 (2 x plugged)
Junction Box/Stowage Point	
Enclosure Material	GRP with carbon loading
Terminals	2 x 2.5 mm ² conductor capacity
Cable Entries	1 x 20 mm
Clamp Cable Connection	Quick Connect
Grounding Clamp	
Clamp Design	2 pole with tungsten carbide teeth
Body	Stainless steel
Certification	Ex II 1 GD T6
Approval	FM Approved
Spiral Cable	
Cable	Blue Cen Stat Hytrel sheath (Static dissipative, chemical & abrasion resistant)
Conductors	2 x 1.00 mm ² copper
Length	15 metres extended (optional cable reel and additional lengths of Hytrel cable available please enquire)

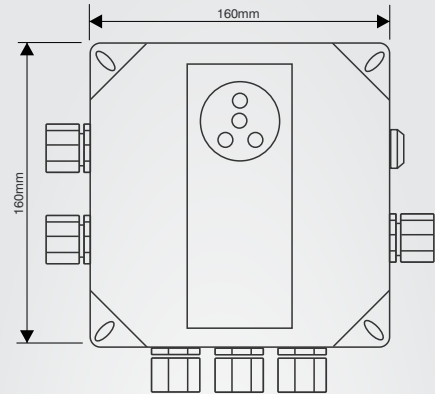

Earth-Rite MGV in certified static dissipative enclosure consisting of ground loop monitoring module and 12V/24V DC power supply for operation in Zone 2, Zone 21 / 22 dust (Class I, II, II, Div.2) atmospheres.

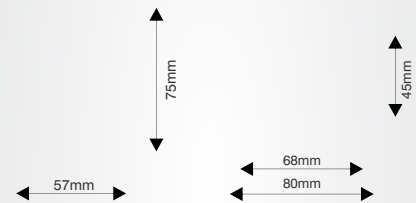

Junction Box/Stowage Point

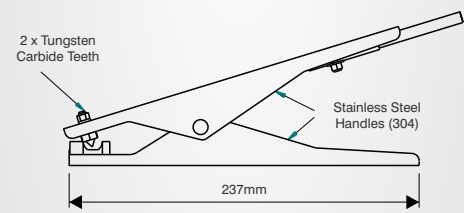

X90-IP - Static Grounding Clamp

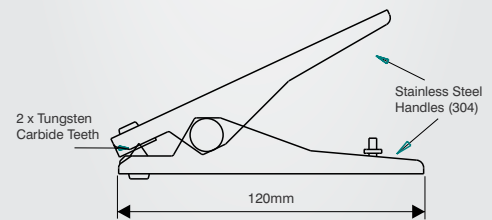

X45-IP - Static Grounding Clamp

ATEX certified / FM Approved 2 Pole stainless steel grounding clamp fitted with one pair of tungsten carbide tips.

Earth-Rite® MGV Mobile Ground Verification System

Hazardous Area Certification

Europe / International:

IECEX

Ex nA nC [ia] IIC T4 Gc(Ga) (gas & vapour).
 Ex tb IIIC T70°C Db (combustible dusts).
 Ta = 40°C to +55°C.
 IECEX SIR 09.0097
 IECEX certifying body: SIRA.

ATEX

Ex II 3(1) G
 Ex II 2D
 Ex nA nC [ia] IIC T4 Gc(Ga)
 Ex tb IIIC T70°C Db
 Ta = 40°C to +55°C.
 Sira 09ATEX2247
 ATEX Notified Body: SIRA.

North America:

NEC 500 / CEC (Class & Division)

Associated Equipment [Ex ia] for use in
 Class I, Div. 2, Groups A, B, C, D;
 Class II, Div. 2, Groups E, F, G
 Class III, Div. 2,
 Providing Intrinsically Safe circuits for
 Class I, Div. 1, Groups A, B, C, D;
 Class II, Div. 1, Groups E, F, G;
 Class III, Div. 1;
 When installed per Control Dwg;
 ERII Q 10165 cCSAus
 Ta = 25°C to +55°C.
 Ta = 13°F to +131°F.

OSHA recognised NRTL: CSA.

NEC 505 & 506 (Class & Zoning)

Class I, Zone 2, (Zone 0), AEx nA[ia] IIC T4
 (gas & vapour).
 Class II, Zone 21, AEx tD[iaD] 21, T70°C,
 (combustible dusts).

CEC Section 18 (Class & Zoning)

Class I, Zone 2 (Zone 0) Ex nA[ia] IIC T4
 DIP A21, IP66, T70°C

Additional Certification

Safety Integrity Level:

SIL 2 (in accordance with IEC/EN 61508).

SIL assessment body:

Exida

EMC Tested:

to EN 61000 6 4, EN 61000 6 2
 FCC Part 15 (Class B)



IECEX



SIL 2



Earth-Rite® MGV Mobile Ground Verification System

Technical Specification

Ex d (Zone 1 Gas / Vapour Installations)

Monitoring Unit	
Power Supply	12 V or 24 V DC
Power Rating	10 watt
Ambient Temperature Range	40°C to +55°C
Ingress Protection	IP 66
Weight	4.5 kgs (9.9 lbs) nett
Construction	Copper free cast aluminium
Monitoring Circuit	Intrinsically safe
Operational Series Ground Resistance	Nominally ≤ 10 Ohm
Output Relay Contact Rating	2 off voltage free change over switch contacts, 250 V AC, 5 A, 500 VA max resistive 30 V DC, 2 A, 60 W max resistive
Cable Entries	7 x M20 (2 x plugged)
Junction Box/Stowage Point	
Enclosure Material	GRP with carbon loading
Terminals	2 x 2.5 mm ² conductor capacity
Cable Entries	1 x 20 mm
Clamp Cable Connection	Quick Connect
Grounding Clamp	
Clamp Design	2 pole with tungsten carbide teeth
Body	Stainless steel
Certification	Ex II 1 GD T6
Approval	FM Approved
Spiral Cable	
Cable	Blue Cen Stat Hytrel sheath (Static dissipative, chemical & abrasion resistant)
Conductors	2 x 1.00 mm ² copper
Length	15 metres extended (optional cable reel and additional lengths of Hytrel cable available please enquire)

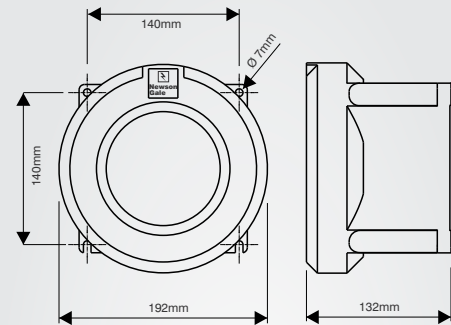

ATEX certified / UL Approved copper free cast aluminium enclosure IP 66

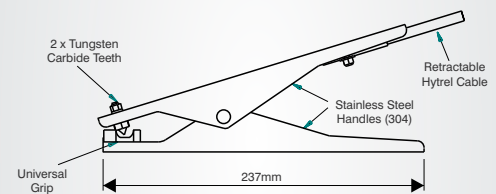

ATEX certified / FM Approved 2 Pole stainless steel grounding clamp fitted with one pair of tungsten carbide tips

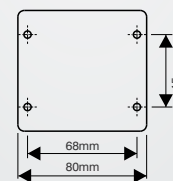
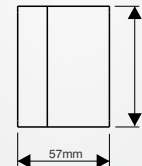

Simple Apparatus GRP Quick Connect junction box.

Earth-Rite® MGV Mobile Ground Verification System

Hazardous Area Certification

Europe / International:

IECEX

Ex d[ia] IIC T6 Gb(Ga) (gas & vapour).
 Ex tb IIIC T80°C IP66 Db (combustible dusts).
 Ta = 40°C to +55°C.
 IECEX SIR 09.0018
 IECEX certifying body: SIRA.

ATEX

Ex II 2(1)GD
 Ex d[ia] IIC T6 Gb(Ga)
 Ex tb IIIC T80°C IP66 Db
 Ta = 40°C to +55°C.
 Sira 09ATEX2047
 ATEX Notified Body: SIRA.

North America:

NEC 500 / CEC (Class & Division)

Associated Equipment [Ex ia] for use in
 Class I, Div. 1, Groups A, B, C, D;
 Class II, Div. 1, Groups E, F, G;
 Class III, Div. 1,
 Providing intrinsically safe circuits for
 Class I, Div. 1, Groups A, B, C, D;
 Class II, Div. 1, Groups E, F, G;
 Class III, Div. 1,
 When installed per Control Dwg;
 ERII Q 10110 cCSAus
 Ta = 25°C to +50°C.
 Ta = 13°F to +122°F.

OSHA recognised NRTL: CSA.

NEC 505 & 506 (Class & Zoning)

Class I, Zone 1 [0] AEx d[ia] IIC T6 Gb(Ga)
 (gas & vapour).
 Class II, Zone 21 [20] AEx tD [iaD] 21 T80°C
 (combustible dusts).

CEC Section 18 (Class & Zoning)

Class I, Zone 1 [0] Ex d[ia] IIC T6 Gb(Ga)
 DIP A21, IP66, T80°C

Additional Certification

Safety Integrity Level:

SIL 2 (in accordance with IEC/EN 61508).

SIL assessment body:

Exida

EMC Tested:

to EN 61000 6 4, EN 61000 6 2
 FCC Part 15 (Class B)



IECEX



SIL 2



Earth-Rite® MGV Mobile Ground Verification System

System Options

Newson Gale supplies a range of product options that enhance the control and general safety of transfer processes and aid engineers with system installations and routine system service checks. Contact Newson Gale or your local Newson Gale representative for more information on the range of options available.

Portable Static Grounding Kit

A quick and easy to use grounding kit which may be swiftly deployed in emergency or combustible material transfer operations where pre-existing designated grounding points are not available or accessible.

The portable grounding kit combines multiple shortened grounding rods (355 mm long) with surface wire grounding techniques to provide acceptably low resistance for static grounding requirements in field operations.

The flexible array of interconnected grounding rods is inserted into the soil at specified intervals to maximize the capacity to safely dissipate static electricity from mobile trucks, service vehicles and other equipment.

- > Kit includes multiple rods, surface grounding wires, ground tab and driver tool.
- > Quick and easy to install and retrieve.
- > Static Grounding Canvas Kit Bag for Portable Grounding Kit and Cen-Stat™ Clamps, Assemblies and Tools.



Portable static grounding kit
Product Code: SWGKP1

VESM02 Retractable Cable Reel

The VESM02 Retractable Cable Reel is supplied for grounding system installations where customers want to ensure the grounding clamp and cable are returned to the static grounding system by operators and drivers on completion of the product transfer process. The **VESM02 Reel** can be used in conjunction with the **Earth-Rite RTR**, **Earth-Rite MGV** and **Earth-Rite PLUS**.

- > Certified for ATEX Zone 1 and 21 hazardous areas.
- > Self-retracting with up to 15 m (50 ft.) of Hytrel® protected cable.
- > Silver plated ultra low resistance slip ring contacts.



VESM02 Retractable Cable Reel
Product Code: VESM02.

Earth-Rite® MGV Mobile Ground Verification System

Earth-Rite MGV Tester

This Tester provides competent electrical personnel with the ability to confirm that the functional characteristics of the Earth-Rite MGV static grounding system are working to parameters that will confirm a truck is safely grounded when deployed in the field. The easy to use tester enables the user to “dial in” a number of settings via a pair of rotary switches that indicate the MGV system is fit for use. The Tester should be used during the installation of MGV systems and during scheduled maintenance for trucks on which MGV systems are installed.

Functional Parameter Tests:

- > **Static Ground Verification**
Ensures the MGV only goes permissive on a value of resistance to True Earth that is capable of dissipating static charges safely.
- > **Continuous Loop Monitoring**
Ensures the MGV system only goes permissive when the connection resistance between the truck and ground source is 10 ohms or less.
- > **Clamp and Cable test**
Ensures good continuity in the circuit through the grounding clamp teeth, conductors and Quick Connect.



Earth-Rite MGV Tester
Product Code: ER2/CRT.

Installer's Kit

This kit provides installation engineers with the necessary Ex (d) enclosure glands (x5) and system cable (x3) required to complete an **Earth-Rite RTR** or **Earth-Rite PLUS** installation as specified in the system installation manuals. Two of the glands cater for both armoured and non-armoured cable diameters ranging from 9 mm to 13.5 mm. Three glands cater for IS current carrying non-armoured cable with cable diameters ranging from 4 mm to 8.4 mm. * For areas not requiring IIC apparatus.

- > Ex (d) IP68 glands (x2) for armoured or non-armoured cable.*
- > Ex (d) IP68 glands (x3) for non-armoured cable (IS outputs).*
- > 3 m length of 2 conductor cable (x1) to connect system enclosure to clamp stowage box.
- > 1 m length of system ground loop cable (x2), with Ex (d) glands, PCB connectors and bolt eyelets attached.
- > 1 pair of handles to aid opening and closing of the enclosure lid.

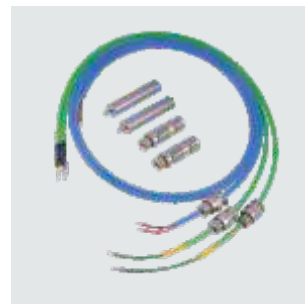

Installer's Kit
Product Code: ER2KITA
(Power cable and interlock cable not supplied).

Earth-Rite® MGV Mobile Ground Verification System

Enquiry > Click here to submit a product related query or a request for quotation.

Application Spotlight Mobile Ground Verification for Trucks

How can I safely ground my truck in places where there's no grounding system to do it for me?

Trucks transferring flammable products require static grounding protection to prevent the build up of static electricity on the truck or equipment, like hoses, that are connected to the truck. If static electricity is allowed to build up on the truck the discharge of a static spark becomes a very real, but unseen, ignition hazard. In terminals equipped with loading racks, static grounding systems ensure static electricity cannot accumulate on the truck during loading or unloading.

However, many trucks recovering or transporting flammable product conduct transfer operations in locations where static grounding systems are not present. This is mostly due to the nature of the operation, which could range from cleaning out a storage tank to delivering product to sites where grounding systems are not installed at the product delivery point.

In situations where grounding system are not present, grounding is usually achieved with a cable reel that bonds the truck to what is assumed to be a functional grounding point. However, it is impossible for a bonding reel to determine if the grounding point will in fact transfer electrostatic charges to ground. It is also not possible to monitor the truck's connection to the grounding point for the duration of the transfer operation, which is risky as the driver will not know if the grounding clamp connection is compromised unless he has a visual confirmation of this.

A truck mounted system like the Earth Rite MGV removes any risk of "false" grounding points being mistakenly used by the driver. By simply connecting the MGV's clamp to the grounding point, the MGV automatically verifies if the grounding point has a connection to the general mass of the Earth that will prevent the build of static charges on the truck. Not only does the MGV ensure the truck is connected to a true Earth ground, it also monitors the truck's connection to the verified ground for the duration of the transfer operation. Structures and equipment that are in permanent contact with the ground (e.g. support beams, motor casings, and fences) can be tested to provide a grounding point for the truck. Even in situations where such options are not present a temporary ground can be tested and established with a set of ground rods.

Should the MGV detect a compromised ground connection two volt free (dry) contacts facilitate the shutdown of the transfer operation, preventing the generation, and subsequent accumulation, of static electricity. This feature, combined with the bright attention grabbing LED ground status indicators, ensure the safety of the operation is enhanced well above the levels provided by basic bonding reels.



Trucks transferring flammable products do not always have access to a static grounding system.



The truck mounted grounding system, the Earth Rite MGV, tests ground points to ensure they are capable of grounding trucks.

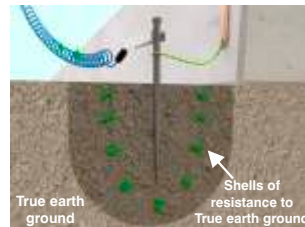

The Earth Rite MGV, ensures the resistance to True Earth is low enough to safely ground the truck.

Earth-Rite® MGVP Mobile Ground Verification System



Product Ordering Codes

Ordering Code	Product Description
MGVP1ED7A4-KC	ER MGVP System with GRP Enclosure + X90IP stainless steel clamp + 15 m retractable Hytrel retractable spiral cable + junction box with Quick Connect. (Option for additional 15 m of retractable spiral cable ask for more details*).
MGVP1ED4A7-KC	ER MGVP System with GRP Enclosure + X90IP stainless steel clamp + M02 Cable Reel with 15 m Hytrel cable. (Additional lengths of cable cannot be used with the M02 cable reel).
MGVMED7A4-KC	ER MGVP System with Ex d Enclosure + X90IP stainless steel clamp + 15 m retractable spiral cable + junction box with Quick Connect. (Option for additional 15 m of retractable spiral cable ask for more details*).
MGVMED7A7-KC	ER MGVP System with Ex d Enclosure + X90IP stainless steel clamp + M02 Cable Reel with 15 m Hytrel cable. (Additional lengths of cable cannot be used with the M02 cable reel).
ER2/KITA	Installer's Kit including specified Ex d armoured glands for areas not requiring IIC apparatus (x2), non armoured system grounding cable (x3) and enclosure lid handles
ER2/CRT	ER MGVP Tester for MGVP system installation commissioning and servicing.
SWGKP1	Portable static grounding kit.
VESM02	VESM02 Retractable Cable Reel with 15 m (50 ft) of 2 conductor Hytrel protected static grounding cable.

* Alternative clamp, cable length and reel options upon request.
Contact your local sales office or distributor with your requirements.

Contact Us > Your enquiry will be processed rapidly via our webform enquiry service. If you would prefer to call us, or e-mail us, please use the contact details provided below.

During product transfer operations the body of the truck is normally situated in Zone 2 / Class I, Div. 2 locations or lower risk areas and these codes reflect the MGVP supplied in static dissipative, impact tested, GRP enclosures. If the MGVP system is likely to be situated in Zone 1 / Class I, Div.1 locations during transfer operations the MGVP can be supplied in an Ex(d) / XP flameproof enclosure. Please contact your local Newson Gale office or Newson Gale sales representative for more information.